

RBM THERMOSTATIC VALVE WITH LOW THERMAL INERTIA

The RBM thermostatic valves and the thermostatic heads are certified in accordance with **European Standard UNI EN 215 (ED. 2007) "Thermostatic valves for radiators. Requirements and test methods"**.

The Standard conformity certifications are guaranteed by the certificates granting use of trademark no. 43, issued by the certifying body.

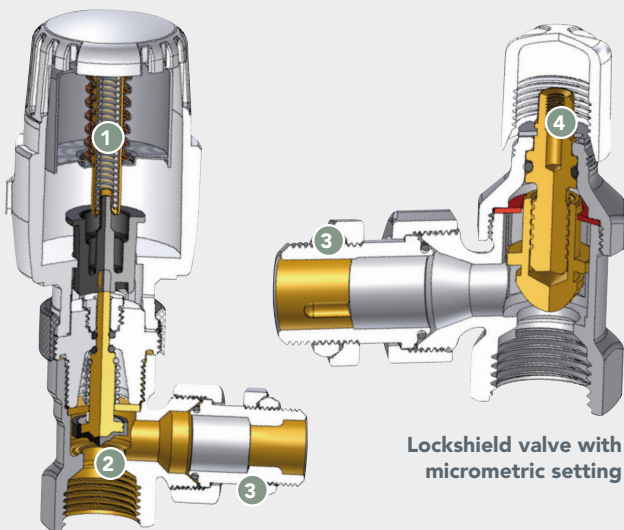

Thermostatic valve

Lockshield valve with micrometric setting

- 1 **Liquid expansion thermostatic sensor**
Higher Sensitivity.
- 2 **Pole with vulcanized elastomer disc**
Elastomer directly vulcanized on the pole disc:
 - Avoids noise
 - Disc does not stick on the valve seat.
- 3 **RFS radiator sealing made in PTFE**
Water sealing vs leakage is assured for a long lasting time.
- 4 **"Heavy" Lockshield valve**
Micrometric setting! Perfect for balancing.
KVS values (min. 9 values) can be set through the hand wheel on the top.



STEM NUT
OR SEAL

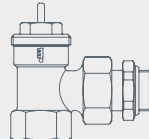

Possibility of maintenance service while system is in operation.



Thermostatic Valve RBM High Energy Efficiency: Class I approved!



The valves' certification in accordance with Standard UNI EN 215, is the RBM thermostatic valve and head combination.